

E1 LIGHTING KIT

DUAL FAA L864/865 & L810

TOWERS FROM 151' TO 350'

INSTALLATION PER FAA ADVISORY CIRCULAR AC70/7460
AND UNITED STATES NATIONAL ELECTRIC CODE NFPA-70.
ALL CABLE AND ACCESSORIES INCLUDED IN KIT.
INSTALLATION DRAWINGS AND BILL OF MATERIAL
PROVIDED WITH PURCHASE.

**OWNER TO FURNISH REQUIRED POWER INPUT,
120/230 VAC, 50/60 HZ
LOAD REQUIREMENT = 100VA**

MISCELLANEOUS ITEMS TO COMPLETE INSTALLATION
BEYOND SCOPE OF KIT DESIGN ARE NOT INCLUDED,
BUT AVAILABLE IF REQUIRED BY SPECIFICATION.

LOWEST POWER & LONGEST LASTING LED SYSTEM
GREEN POWER COST SAVINGS
MEETS ROHS COMPLIANCE
FIVE YEAR WARRANTY

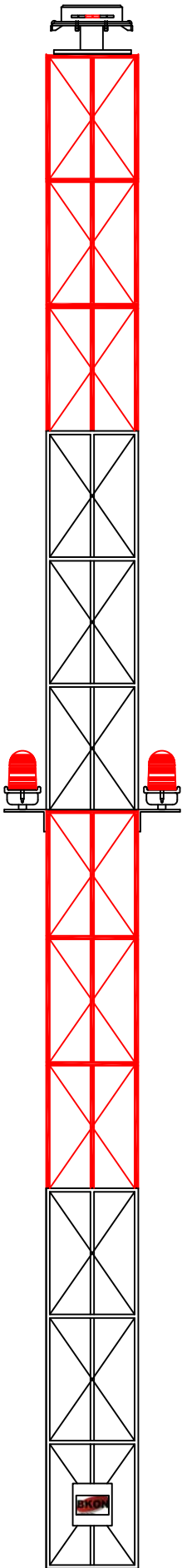

124 South Street
Franklin, KY 42134

Tel: 270-598-8859

Fax: 270-598-8797

TOLL FREE: 1-800-621-4419





LOCATION USA E1 DUAL TOWER KIT
151'-350'
DRAWING NO. E108KITBIDSKETCH DATE 10-6-10
SCALE N.T.S.

FAA APPROVED 100W DAY/20W NIGHT
WHITE & RED MEDIUM INTENSITY FLASHING LED BEACON

- KIT INCLUDES:**
- LED BEACON
 - POWER SUPPLY
 - LED MARKERS
 - BEACON CABLE
 - MARKER CABLE
 - SUPPORTS
 - PHOTO CONTROL
 - MISC. HARDWARE & CONNECTORS
 - INSTALLATION DRAWING

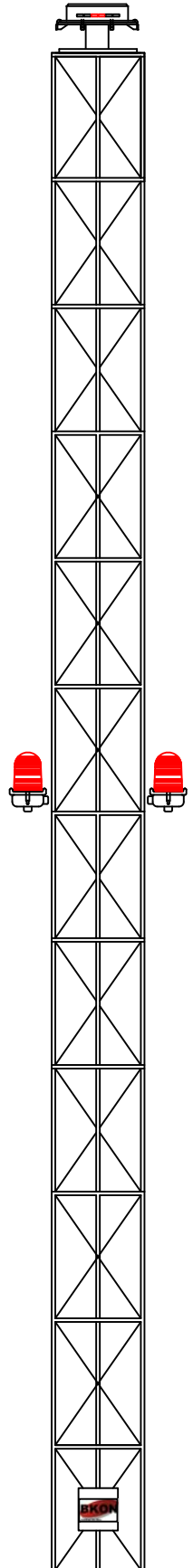

TOP LEVEL

FACTORY CABLE

STEADY RED LED MARKER LIGHT

J-BOX (TYP)

MID LEVEL

FACTORY CABLE

PHOTOCELL

DUAL RED/WHITE LED POWER SUPPLY

TO OWNER FURNISHED 120/230 VAC
TOTAL CONNECTED LOAD: 100VA

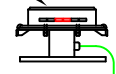



E1 STACK LIGHTING KIT

DUAL FAA L864/865 & L810

STACKS FROM 151' TO 350'

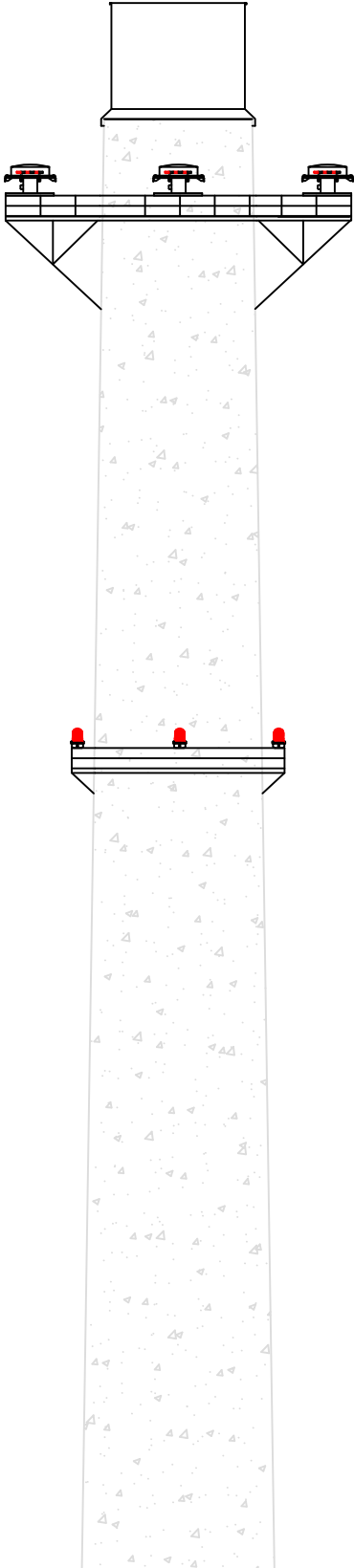

INSTALLATION PER FAA ADVISORY CIRCULAR AC70/7460
AND UNITED STATES NATIONAL ELECTRIC CODE NFPA-70.
ALL CABLE AND ACCESSORIES INCLUDED IN KIT.
INSTALLATION DRAWINGS AND BILL OF MATERIAL
PROVIDED WITH PURCHASE.

**OWNER TO FURNISH REQUIRED POWER INPUT,
120/230 VAC, 50/60 HZ & 48VDC
TOTAL LOAD REQUIREMENT = 35VA**

MISCELLANEOUS ITEMS TO COMPLETE INSTALLATION
BEYOND SCOPE OF KIT DESIGN ARE NOT INCLUDED,
BUT AVAILABLE IF REQUIRED BY SPECIFICATION.

LOWEST POWER & LONGEST LASTING LED SYSTEM
GREEN POWER COST SAVINGS
MEETS ROHS COMPLIANCE
FIVE YEAR WARRANTY

124 South Street
Franklin, KY 42134
Tel: 270-598-8859
Fax: 270-598-8797

TOLL FREE: 1-800-621-4419



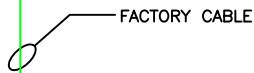
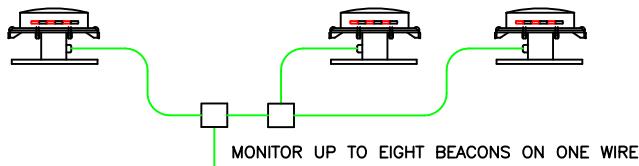

- KIT INCLUDES:**
- LED BEACONS
 - LED MARKERS
 - BEACON CABLE
 - MARKER CABLE
 - SUPPORTS
 - PHOTO CONTROL
 - MISC. HARDWARE & CONNECTORS
 - INSTALLATION DRAWING

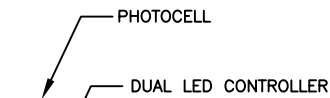
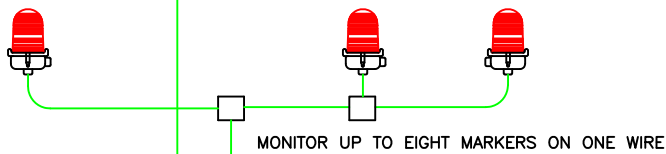

STACK KIT

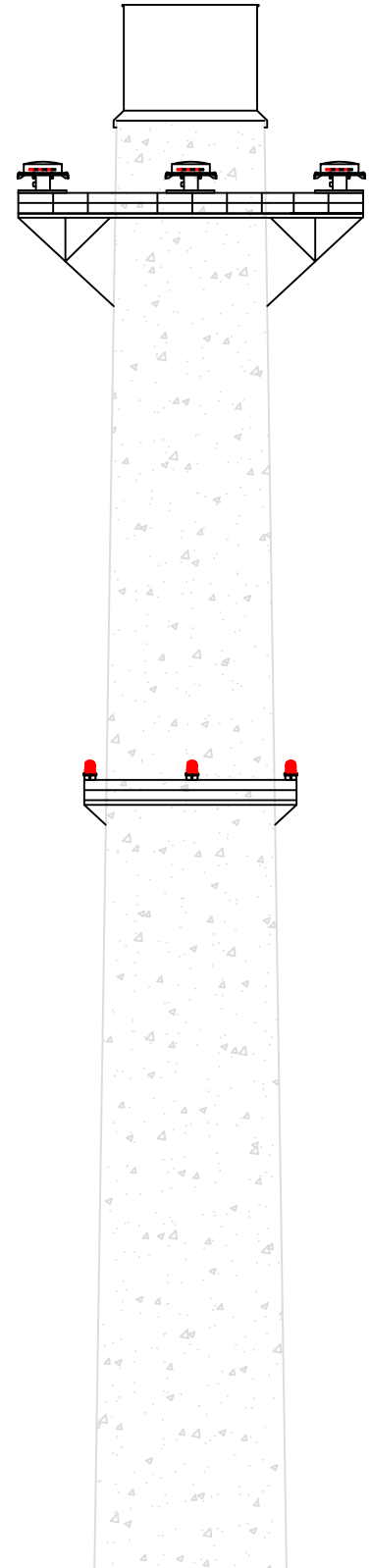

* STACKS EXCEEDING 20 FT. IN DIAMETER WILL REQUIRE FOUR LIGHTS PER LEVEL